

# Gocator® 2300 Series

## ALL-IN-ONE 3D SMART PROFILE SENSORS

The Gocator 2300 series of 3D smart sensors are designed for the demanding industrial conditions of the factory floor. Gocator's simple and flexible design enables factories to reduce costs and maximize profitability by improving efficiencies in product validation. The Gocator 2300 series comes in various models but can also be customized to suit specific factory automation requirements.

- PRE-CALIBRATED TO SCAN MICRON-LEVEL DETAILS
- HIGH SPEED & LOW LATENCY
- SETUP & CONTROL VIA WEB BROWSER
- BUILT-IN TOOLS, NO PROGRAMMING
- OPEN SOURCE SDK



### MEGAPIXEL RESOLUTION

Gocator 2300 sensors measure micron level features leveraging megapixel resolution while maintaining large fields of view. Gocator can now screen parts for very small defects, raising the bar for quality inspection.

### STANDALONE & SCALABLE

Single sensors require no additional controllers, amplifiers or PCs. Gocator systems can effortlessly scale to multiple sensors using LMI Master hubs. Masters take care of power distribution, laser safety interlock, encoder and digital input handling, and microsecond synchronization.

### COMPACT & LIGHT WEIGHT

Gocator's small footprint and less than 1.5 kg weight make it ideal for fitting into tight spaces and mounting onto robotic arms.

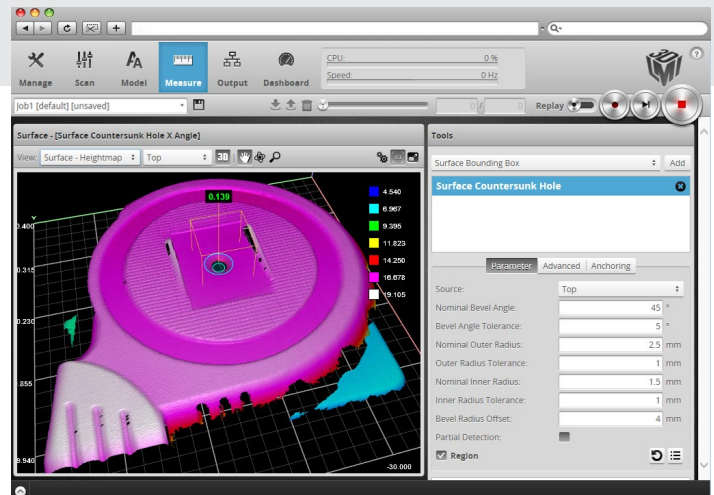

Gocator's browser-based graphical user interface

### EASY TO USE

Gocator's built-in GUI allows for flexible configuration of profiling settings and measurement tools using any web browser, computer or operating system. With no additional software to install, Gocator's out of the box setup and configuration is fast and easy.

GOCATOR 2300 SERIES MODELS	2320	2330	2340	2350	2370	2375	2380
Data Points / Profile	1280	1280	1280	1280	1280	1280	1280
Linearity Z (+/- % of MR)	0.01	0.01	0.01	0.01	0.04	0.03	0.04
Resolution Z (mm)	0.0018 - 0.0030	0.006 - 0.014	0.013 - 0.037	0.019 - 0.060	0.055 - 0.200	0.175 - 0.925	0.092 - 0.488
Resolution X (mm) (Profile Data Interval)	0.014 - 0.021	0.044 - 0.075	0.095 - 0.170	0.150 - 0.300	0.275 - 0.550	0.255 - 0.790	0.375 - 1.100
Repeatability Z (µm)	0.4	0.8	1.2	2	8	12	12
Clearance Distance (CD) (mm)	40	90	190	300	400	650	350
Measurement Range (MR) (mm)	25	80	210	400	500	1350	800
Field of View (FOV) (mm)	18 - 26	47 - 85	96 - 194	158 - 365	308 - 687	324 - 1010	390 - 1260
Laser Classes	2, 3R	2, 3R, 3B	2, 3R, 3B	2, 3R, 3B	2, 3R	2, 3R	2, 3R
Dimensions (mm)	Side Mount 35x120x149.5	Top Mount 49x75x142	Top Mount 49x75x197	Top Mount 49x75x272	Top Mount 49x75x272	Top Mount 49x75x272	Top Mount 49x75x272
Weight (kg)	0.8	0.74	0.94	1.3	1.3	1.3	1.3

Optical models, laser classes, and packages can be customized. Contact LMI for more details.  
 Specifications stated are based on standard laser classes. Linearity Z, Resolution Z, and Repeatability Z may vary for other laser classes.  
 Refer to specifications in the Gocator Line Profile Sensor user manual for more details.

#### ALL 2300 SERIES MODELS

Scan Rate	Approximately 170 Hz to 5000 Hz
Interface	Gigabit Ethernet
Inputs	Differential Encoder, Laser Safety Enable, Trigger
Outputs	2x Digital output, RS-485 Serial (115 kBaud)
Input Voltage (Power)	+24 to +48 VDC (13 Watts); Ripple +/- 10%
Housing	Gasketed aluminum enclosure, IP67
Operating Temperature	0 to 50°C
Storage Temperature	-30 to 70°C
Vibration Resistance	10 to 55 Hz, 1.5 mm double amplitude in X, Y, and Z directions, 2 hours per direction
Shock Resistance	15 g, half sine wave, 11 ms, positive and negative for X, Y, and Z directions
Scanning Software	Browser-based GUI and open source SDK for configuration and real-time 3D visualization. Open source SDK, native drivers, and industrial protocols for integration with user applications, third-party image processing applications, and PLCs.

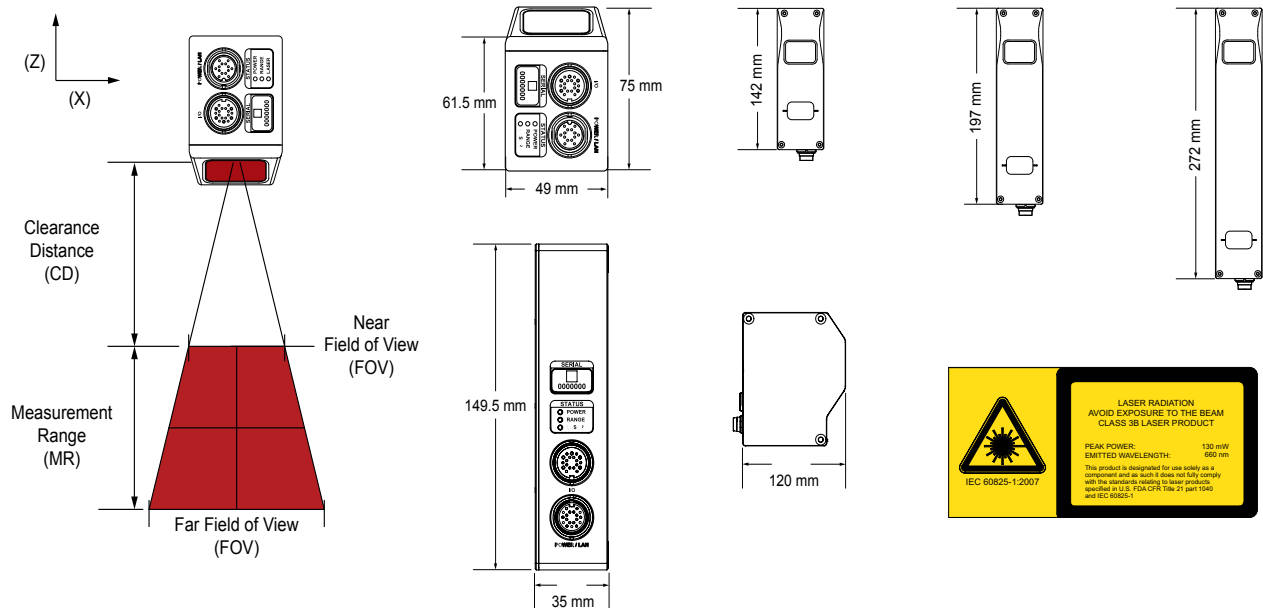

**AMERICAS**  
 LMI Technologies Inc.  
 Burnaby, BC, Canada

**EMEAR**  
 LMI Technologies GmbH  
 Teltow/Berlin, Germany

**ASIA PACIFIC**  
 LMI (Shanghai) Trading Co., Ltd.  
 Shanghai, China



LMI Technologies has offices worldwide. All contact information is listed at [lmi3d.com/contact/locations](http://lmi3d.com/contact/locations)